

# Case to Counter CA605

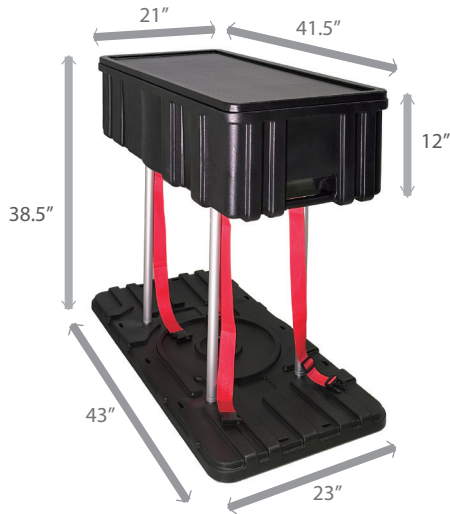

## PARTS INCLUDED



## PRODUCT DESCRIPTION

The CA605 case redefines convenience and versatility with its robust features. Crafted from heavy-duty plastic, it ensures durability while providing effortless mobility with integrated wheels. Its clever design includes ample storage spaces for organized accessibility. Transforming into a counter without the hassle of tools, this case offers a seamless setup experience.

Adding to its appeal, vibrant graphics are printed on exclusive One Planet fabrics that not only elevate its aesthetics but also highlight its commitment to sustainability. The CA605 stands as a testament to functionality, durability, and eco-friendly innovation, catering perfectly to those in need of a multifaceted and reliable solution.

## KEY FEATURES

- Heavy duty plastic case
- Clever storage space
- Wheels for easy portability
- Durable aluminum poles
- Case converts to counter
- Black or full color graphic prints on recycled fabrics
- Easy tool-free assembly

## DISPLAY CONSTRUCTION

Heavy duty plastic with aluminum support poles

## GRAPHIC MATERIAL

Graphic Print :  
Dye sublimated on One Planet, 100% recycled,  
fabric

Bottles recycled  
**40**

## DIMENSIONS

Case Dimensions	43" w x 13.5" h x 23" d, 37 lbs
Case (Interior)	40.5" w x 19" h x 12" d
Counter (Exterior)	43" w x 38.5" h x 21" d
Shipping Box	44" w x 15" h x 24" d, 39 lbs

## WARRANTY

Limited Warranty Periods  
- Case : 90 days  
- Graphics : 30 days

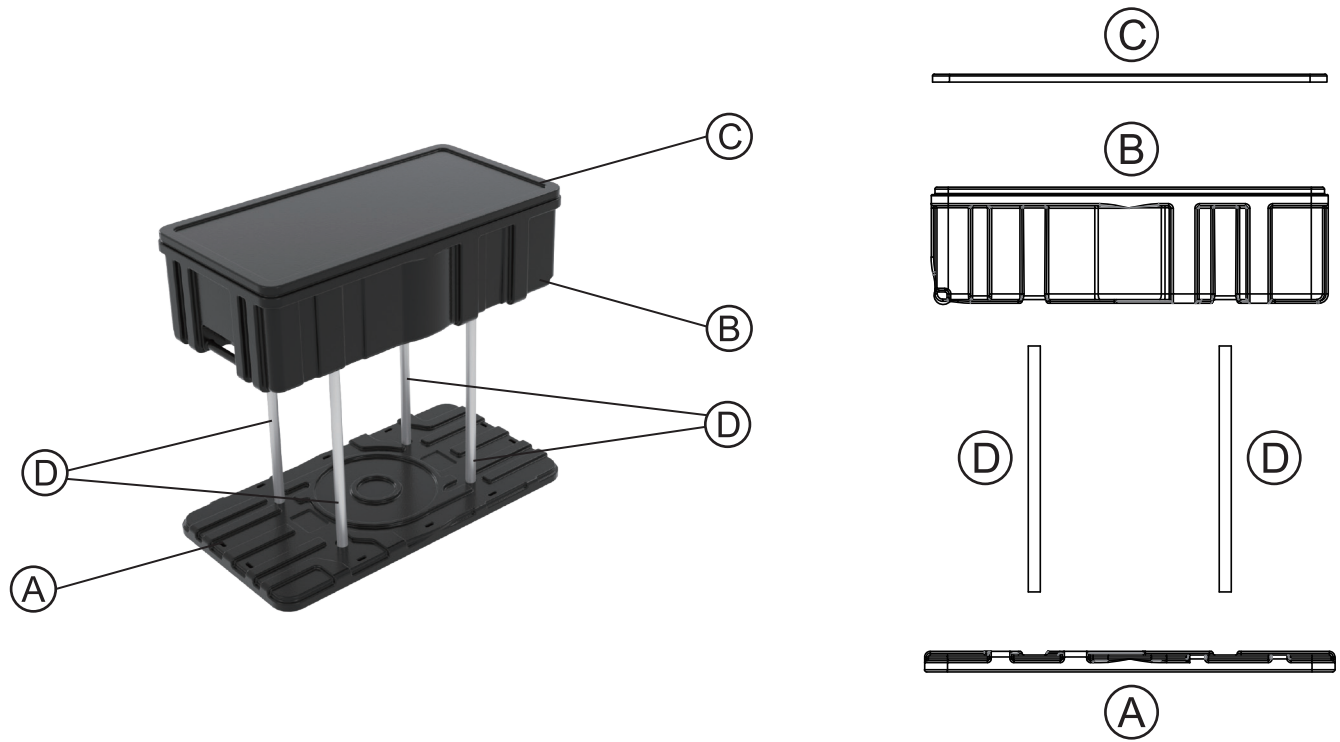

ASSEMBLY

Assemble parts on the floor and stand-up unit when completed.

